



HLPT520B5H3I6 环境光传感器是一款高灵敏度的光敏传感器, 插件式外型封装, 是传统 CDS 光敏电阻的理想替代产品, 模拟人眼感光, 峰值波长 520nm, 专用于红外监控类产品, 控制红外灯低照度下开启。

HLPT520B5H3I6 is a high sensitivity optical sensor, in DIP package. It's the ideal substitute for traditional CDS photosensitive resistor, Simulation of the human eye sensitivity, the peak wavelength of 520nm, dedicated to the infrared monitoring products, control the infrared light under low illumination opening.

### 特性 Features

- 1) 感光峰值波长 520nm Photosensitive peak wavelength  $\lambda_p=520\text{nm}$
- 2) 高可靠性 High reliability
- 3) 低功耗 Low Power Consumption
- 4) 符合 RoHS RoHS compliant

### 应用 Applications

- 1) 替代传统 CDS 光敏电阻 Replacement of conventional CDS photosensitive resistors
- 2) 适用于各类光控照明产品: 如小夜灯等 Suitable for all kinds of light products: such as night lamp etc.
- 3) 自动调节背景光: 如 LCD、手机、照像机、电脑摄像头等 Products which need to adjust background light automatically, LCD, mobile phone, camera, computer camera etc.
- 4) 控制各类光控影控玩具 Control all kinds of light and shadow controlled toys
- 5) 各类光控红外检测测试设备等 All kinds of infrared light detection and testing equipment

### 量身订制 Customization

- 1) 品种齐全, 生产周期短, 小批量库存备货 Complete varieties, short production cycle, small batch inventory
- 2) 可按要求提供不同外型, 角度, 方便安装于产品的任何位置 Customize different shapes and angles
- 3) 可按需求提供最佳的规格, 以便让产品效果更好, 更具市场竞争力 Customize most suitable specifications to make the product be more competitive

### 额定参数 Absolute Maximum Ratings (Ta=25°C)

电气特性 Electrical characteristics	Symbol	Rated Value		Unit
工作电压 Operating voltage	Vcc	Min.	Max.	V
		1	10	V
功耗 Power Dissipation	PC	70		mW
工作温度 Operating Temperature	Topr	-30--+85		°C
储存温度 Storage Temperature	Tstg	-40--+100		°C

## 光电特性 Elector-Optical Characteristics (Ta=25°C)

参数	Parameter	Symbol	Test Condition	Min.	Typ.	Max.	Unit
感光峰值波长	Photosensitive peak wavelength	$\lambda_p$	\	--	520	--	nm
感光波宽范围	Sensitivity wave width	$\lambda$	\	400	--	700	nm
工作电压	Operating voltage	VCC	\	--	5	--	V
光电流	Photo-current	IL(1)	VCC=5V Ev=10Lux	2.5	5.0	7.5	$\mu$ A
		IL(2)	VCC=5V Ev=30Lux	7.5	15	22.5	$\mu$ A
		IL(3)	VCC=5V Ev=100Lux	25	50	75	$\mu$ A
暗电流	Dark current	ID	VCC=5V/85°C Ev=0Lux	--	--	0.4	$\mu$ A
红外接收电流	Infrared Light Current	IIR	VCC=5V/850nm IR led Standard	--	--	1	$\mu$ A
开启时间	Rise time	tr	VCC=5V IC=1mA RL=1000 $\Omega$	4.5			ms
关闭时间	Fall time	tf		4.5			

## 可靠性试验 Reliability Test

测试项目	Test Parameter	参考标准	测试条件	时间	样品数	Ac/Re
		Reference Criterion	Test Condition	Time	Quantity	
耐焊接热	Resistance to Solder Heat	JESD22-B106	260°C $\pm$ 5°C	10 sec	22PCS	0/1
	冷热循环 temperature cycle	JESD22-A104	+100°C(15min) 5min -10°C(15min)	50 cycles	22PCS	0/1
	冷热冲击 Thermal Shock	JESD22-A104	+105°C(30min) 5min -45°C(30min)	50 cycles	22PCS	0/1
高温贮存	High Temperature storage	JESD22-A103	+100°C	1000H	22PCS	0/1
低温贮存	Low Temperature storage	JESD22-A119	-40°C	1000H	22PCS	0/1
寿命测试	Life Test	JESD22-A108	VCC=5V	1000H	22PCS	0/1
高温高湿	High Temperature and High Humidity Test	JESD22-A101	85°C&85%R.H	168H	22PCS	0/1

## 光电特性曲线

### Typical photoelectric characteristics curves

感光特性曲线

Photographic  
property Curve

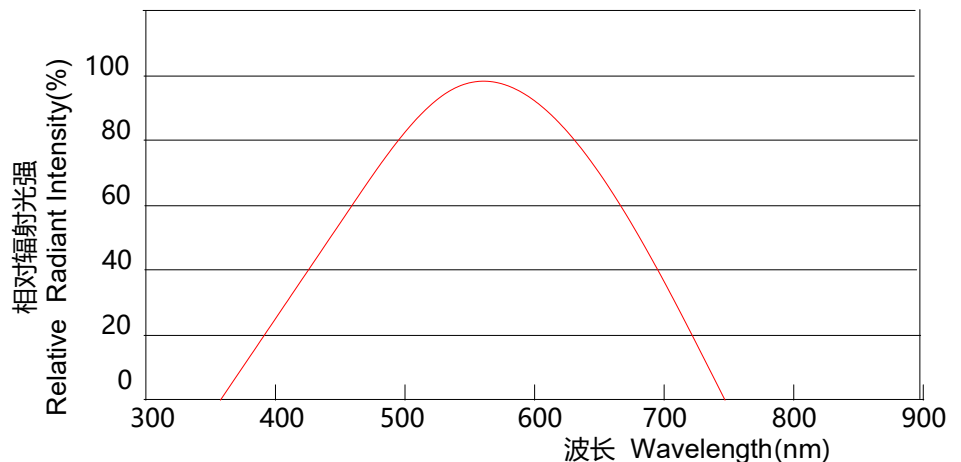

## 暗电流随温度变化曲线

Environment Temperature  
VS Dark Current

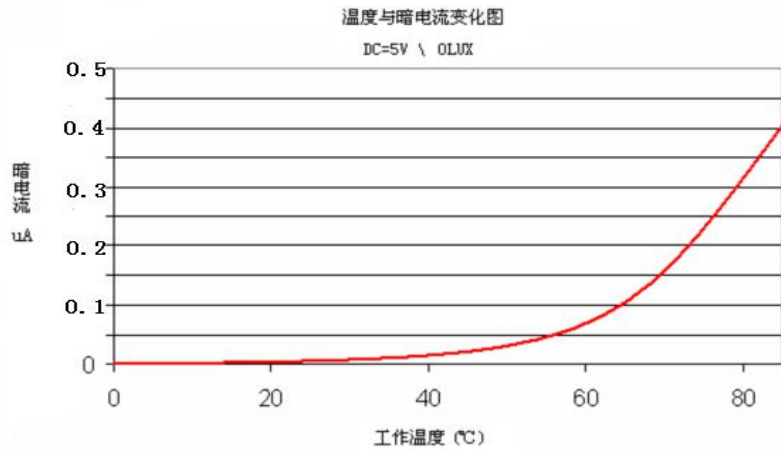

## 应用电路 Application

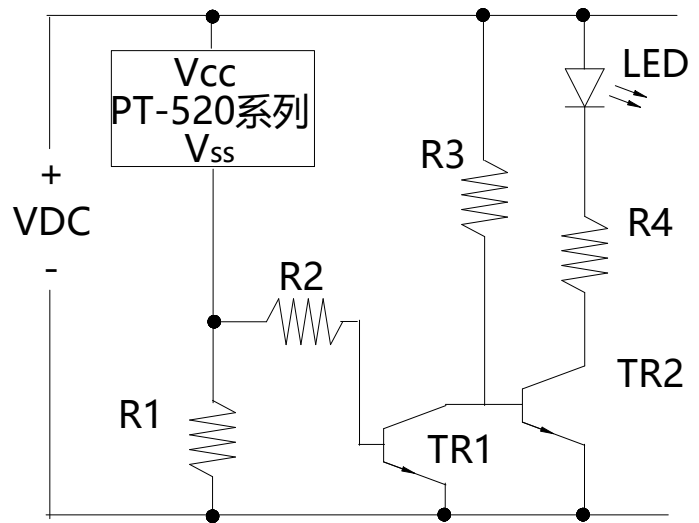
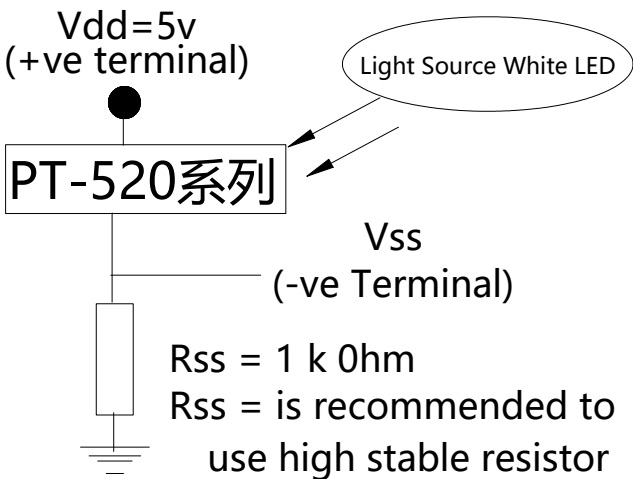

当光照低于光照阈值时，TR1三极管关闭，TR2三极管导通，LED导通。当环境光照大于光照阈值时，TR1降低的电流并使TR2截止，LED不导通。

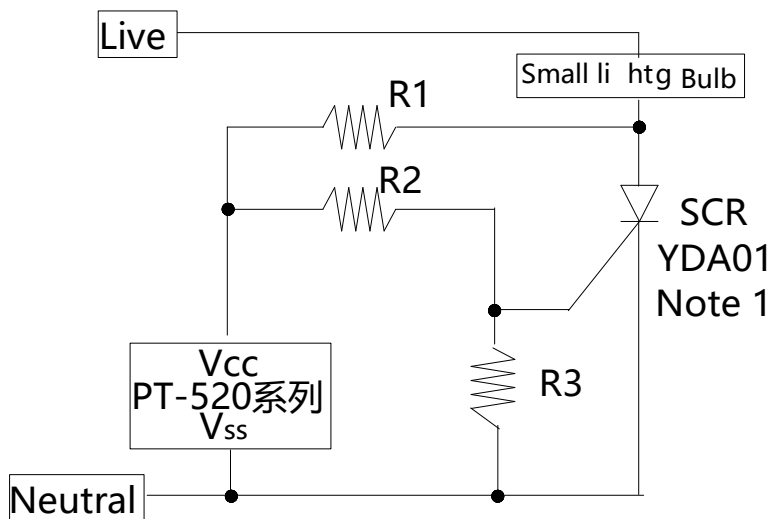

该电路需要一个敏感的可控硅。灯泡的电流是由敏感的可控硅开关空置。当光量超过阈值时，该Vdd与Vss引脚之间的电流转移了可控硅的栅极电流。光切换阈值可通过选择R2和R3不同的值进行调整。

产品外型尺寸  
Package outline dimensions

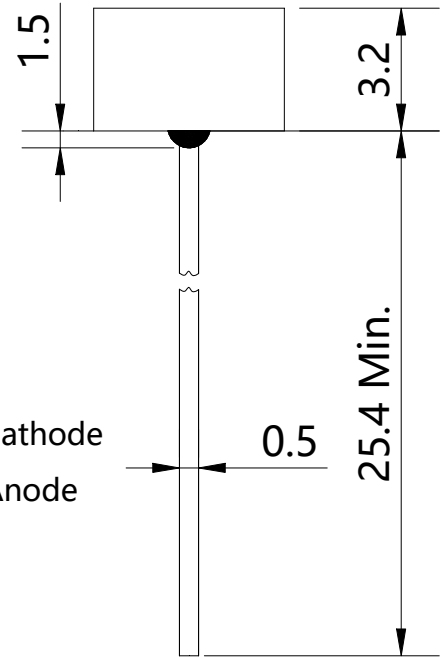
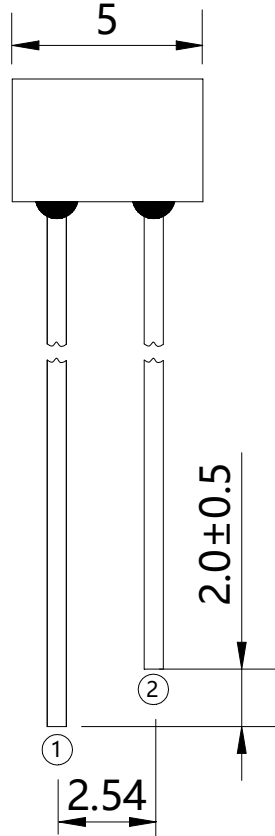
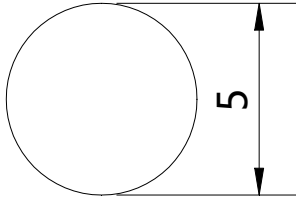

① Cathode  
② Anode

备注：所有尺寸单位均为 mm，  
如无特殊说明误差范围为 ±0.15mm

Note: All dimensions in mm,  
tolerance is ±0.15mm unless  
otherwise noted

包装规格

Packing Specification

- 标签规格 Label specification

 深圳市晶创和立科技有限公司	
产品名称	
规格型号	
订单编号	
物料编号	
产品数量	
发货时间	

- 防静电袋包装

Anti-static bag packing

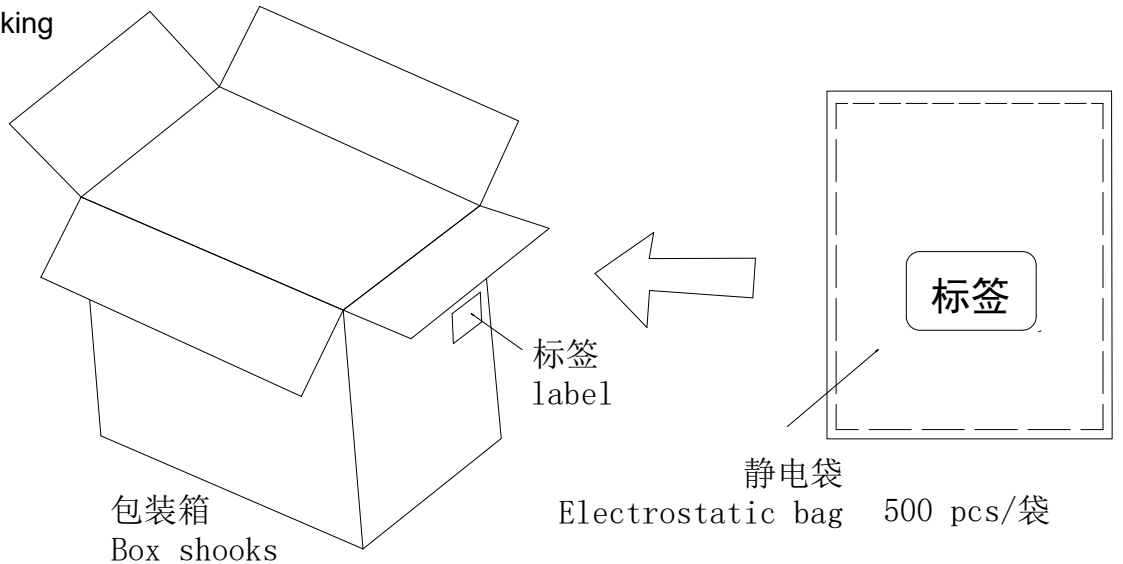

## 焊接 Soldering

焊接过程中的不慎操作将会引起产品的损坏,请务必注意。焊接过程中应避免对产品支架或封装部分施加压力。焊接时,请保证焊接位置与封装树脂底部有一定的距离,该距离因不同的焊接方法而有所不同,请参照以下推荐焊接条件。 Damages may be caused during soldering, please be careful. Please note that don't put stress on product bracket or package part when soldering. And make sure keep some distance from soldering joint to the bottom of epoxy package when soldering. The distance is determined by different soldering techniques, it's recommended to take following soldering conditions as reference.

### 推荐焊接条件 Recommended Soldering Conditions

焊接模式 Mode		固定形式 Fixed form
手工焊接 Manually Soldering	烙铁温度 Soldering Iron Temperature	最高温度 300°C(功率最大 30 瓦) Max 300°C (power:30w Max)
	焊接时间 Soldering Time	时间不超过 3 秒 3 sec Max.
	焊接位置 Soldering Position	大于 3mm (从焊点到胶体) 3mm Min.(Form soldering joint to colloid)
波峰焊接 Wave Soldering	预热 Preheat	最高温度 100°C 不超过 60 秒 100°C Max.60 sec.Max.
	温度 Temperature	最高 260°C 260°C Max.
	焊接时间 Soldering Time	不超过 5 秒 5 sec Max.
锡炉焊接 Solder pot Soldering	预热 Preheat	最高温度 100°C 不超过 60 秒 100°C Max.60 sec.Max.
	浸焊温度 Preheat Temperature	最高 260°C 260°C Max.
	浸焊时间 Soldering Time	不超过 5 秒 5 sec Max.
	焊接位置 Soldering Position	大于 2mm (从焊点到胶体) 2mm Min.(Form soldering joint to colloid)

- 本产品不适合做回流焊接。It's unsuitable for reflow soldering.
- 手工焊接只可焊接一次。Manually soldering should be done once only.
- 器件外部温度在 40°C 以下时,才可以对其进行处理。避免高温时操作对 ALS 造成损伤。Please solder the ALS under 40 degree to avoid high temperature damage the device
- 在焊接温度回到正常以前,必须避免使 ALS 受到任何震动或外力 After soldering the ALS ,please keep it out of any shake or outer force before it come to normal temperature
- 在焊接后推荐使用酒精进行清洗,在温度不高于 30°C 的条件下持续 1 分钟,不高于 50°C 的条件下持续 30 秒。使用其他类似溶剂清洗前,请先确认使用的溶剂不会对 ALS 的封装和环氧树脂部分造成损伤。It is recommended that to use alcohol clean ALS after soldering.Cleaning should be done under 30°C for 1 minute or 50°C for 30 seconds.When using other solvents,please confirm whether the solvents would dissolve the package or resin beforehand .

注意:此一般指导原则并不适用于所有 PCB 设计和焊接设备的配置。具体工艺受到诸多因素的影响,请根据特定的 PCB 设计和焊接设备来确定焊接方案。Note: This general guideline may not suitable for all PCB designs or all soldering equipment configurations. The technique in practice is influenced by many factors.Please confirm soldering method by the PCB designs and configurations.

## 使用注意事项 Precautions

### ■ 储存 Storage

- 在温度不高于 30°C，湿度不高于 60%RH 的条件下，产品保存期限为 6 个月。将产品保存在密封的容器中并附带干燥剂可以在一定程度上延续产品的储存日期。不良的储存条件会导致产品引脚的腐蚀或产品性能的改变。Under the storage conditions of 30°C or less and humidity less than 60%RH, the ALSs storage period is 6months. Stored in a sealed container with moisture absorbent , storage time can be prolonged to a certain extent .Bad storage conditions may cause the ALS pin corrode or ALS characteristics be changed. It is recommended that the ALSs be used as soon as possible.
- 开封后,产品必须 24 小时内使用完(建议工作环境温度不高于 30°C,湿度不高于 60%),如未使用完,余料须存放在温度 不高于 30°C,湿度不高于 10%的环境中。After opening the package, the product should be soldered within 24 hours. If not, please store at 30°C or less and humidity less than 10%RH. It is recommended that the product be operated at the workshop condition of 30°C or less and humidity less than 60%RH.
- 对于尚未焊接的环境光传感器,如果吸湿剂或包装失效,或者产品没有符合以上有效存储条件,烘烤可以起到一定的性能恢复效果.烘烤条件:65±5°C,持续时间 24H。For the ALS doesn't soldered ,if the moisture absorbent material lose efficacy or the storage condition doesn't conform to the above description,baking can help some extent performance recovery .Backing condition : 65±5°C for 24 hours.

### ■ 静电 Static electricity

- 静电和电涌会导致产品特性发生改变，例如正向电压降低等，如果情况严重甚至会损毁产品，所以在使用时必须采取有效的防静电措施。所有相关的设备和机器都应该正确的接地，同时必须采取其他防静电和电涌的措施。使用防静电手环，防静电垫子，防静电工作服，工作鞋，手套，防静电容器，都是有效的防止静电和电涌的措施。Static and electric surge would change the features of ALS, such as decreasing of forward voltage.Even damages may occur in serious conditions.Please make sure adopt effective anti-static measures. All the relative devices and machinery must be properly grounded. At the same time, it is recommended to use anti-static wrist bands,anti-electrostatic gloves, anti-electrostatic containers and so on to prevent static and electric surge.

### ■ 设计建议 Design Suggestion

- 设计电路时，加载在环境光传感器两端的电压不能超过规定的最大值，同时还需要使用分压电阻，以便产品在有光照的情况下将电流变化转换为电压变化，以电压变化进行结果输出从而达到电路控制的效果。When design the circuit, the voltage loaded on the both ends of the ALS should not exceed the specified maximum value, and the pressure resistance should be used to let product convert current change to voltage changes during illumination,in that to achieve the effect of control circuit.
- 环境光传感器的特性容易因为其他电子元件的发热和环境的温度的改变而发生变化。温度的升高会使电子的漂移运动加剧增大暗电流，影响原先产品的电路设计，所以在设计时应充分考虑散热的问题和使用环境的问题。The characteristics of ALS are easily to be effected by the heat of other electronic components and the temperature changes of environment. High temperature would intensify the electrons drift motion then cause dark current increases and affect the original circuit design.So the design should take full account of the heat problem and environment problem.

### ■ 支架整形 Lead Forming

- 支架的整形必须在焊接之前进行。整形时，支架的弯曲位置必须至少在封装树脂底部 3mm 处，同时避免对同一位置进行多次的弯曲。Any lead forming must be done before soldering, not during or after soldering. When forming leads ,the leads should be bent at least 3mm from the base of the expose bulb. Avoid bending at the same position twice or even more.
- 整形时请使用合适的工具固定支架，避免对树脂施加压力。特别是不能管脚与树脂的连接部分作为支点，这样产生的应力会直接对产品内部的发光结构造成损伤，导致产品特性的改变甚至损毁。Please use proper tools to hold the leads.Avoid put press on resin especially don't regard connection part of pin and resin as fulcrum,the pressure caused by it would damage the inner part of product illumination structure,and would change the characters or even damage of the product.
- 基于同样的原因，在装配产品的时候，PCB 板上焊孔间的距离必须于产品的管脚间距严格匹配。For the same reason, when mounting the ALS on to printed circuit board, the holes on the circuit board should exactly aligned with the leads of the ALS.